



# Automag

Self-purging, fully  
automated magnetic filter

# Automag self-purging magnetic filter

The Automag magnetic filter from Eclipse Magnetics uses powerful 'rare earth' magnetic material to improve the quality, efficiency and performance of manufacturing and finishing processes.

The fully automatic, self purging unit effectively removes all magnetic debris, down to sub-micron size, from cutting fluids and oils. This ensures clean fluid is available at the cutting face, resulting in enhanced surface finish and accuracy.

The filter does not use consumables, unlike cartridge and bag filters, operates without user intervention and requires only a small amount of compressed air to operate the cleaning process. Running costs are extremely low.

Payback can be calculated in months rather than years.

Automag can also benefit many other manufacturing applications – from industrial part washing systems to vehicle pre-paint body washing stations and any other applications that rely on a clean supply of filtered fluid.

6, 8 and 12 core units are supplied.

## Automag magnetic filters are used effectively in these applications:

- Grinding, honing & lapping machines
- CNC machinery
- Fine finishing operations
- Industrial part washing
- Post drill head operations
- Circular saw sharpening
- Pump protection
- Pre-filtration
- Quenching operations

## in the following sectors

- Machine tools
- Manufacturing
- Automotive
- Hydraulic
- Marine
- Oil
- Transport
- Water
- Yellow & white goods

## HOW AUTOMAG WORKS

Contaminated fluid enters the inlet port where it is dispersed into the first filtration chamber. The fluid passes around the high-intensity 'rare earth' magnetic cores where contamination particles are removed. The fluid is slowed and enters the second filtration chamber where it receives further filtration.

Contamination remains attached to the stainless steel sleeves of the cores. The filtered fluid exits through the outlet port.

The geometry of the magnetic flux circuit ensures a controlled build up of contamination so the filter can never block.

The purging process is fully automated. The cores are raised from the sleeves and the purge valve is switched. Fluid is pumped through the filter, washing the contamination from the unit.

## In operation

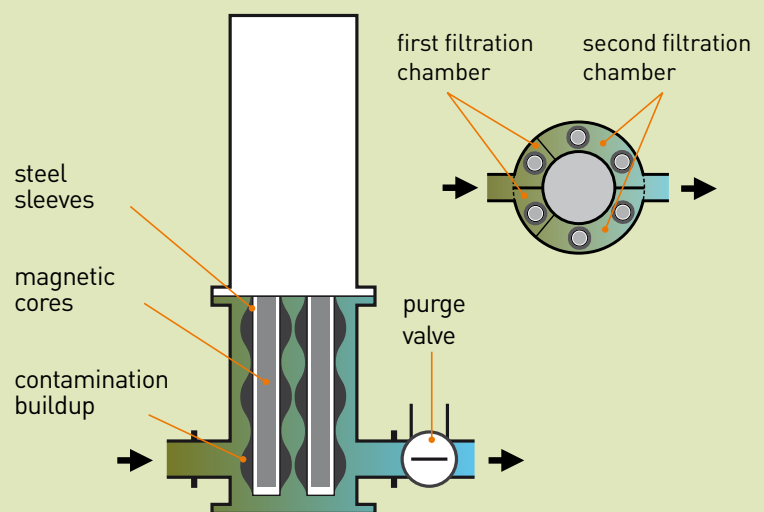

Contamination is attracted to the sleeve of the cores. Cleaned fluid is re-circulated.

# magnetic filter

## Fluid flow configuration

A unique two chamber flow configuration ensures that maximum filtration efficiency is achieved. Fluid is slowed in the Automag and evenly distributed around the magnetic cores.

## Magnetic cores

The magnetic cores are made using 'rare earth' neodymium iron boron – currently the strongest permanent magnet material available. When configured with pole concentrators, high-intensity magnetic fields are generated which are capable of attracting even sub-micron sized particles.

Each core is housed inside a stainless steel sleeve. The cores are held together in a moveable 'shuttle' unit. Cleaning is triggered by a small amount of compressed air moving the shuttle up out of the these sleeves. The contamination, which has been held to the surface of the sleeve by the magnetic field, is then released, allowing it to be purged from the unit.

## Purging

The purge valve is automatically opened as part of the cleaning process. This redirects the fluid into a contamination collection tank. A fixed amount of fluid is allowed through the Automag, purging the contamination into this tank where it can be recycled and reclaimed.

## Purging

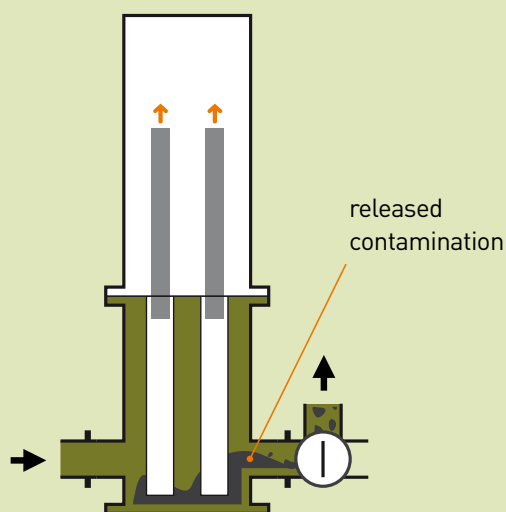

Compressed air lifts the cores from the sleeves and the purge valve is opened. Contamination is released and washed away for collection.



# Magnetic coolant roller

A magnetic coolant roller should be used to separate the fluid and contamination output by the Automag's purging process.

## Reduced fluid waste and disposal costs

The contamination is removed by the coolant filter in the form of a semi-dry metallic cake which can be recycled.

The extracted fluid can be re-used.

## How it works

Contaminated fluid is fed into the inlet feed tray where it spreads evenly. The fluid passes the adjustable baffle plate and onto the magnetic roll which attracts and holds the contamination. The contamination particles follow the rotation of the roll around to the cleaning scraper blade. This wipes off any collected contamination allowing it to fall freely into a collection bin.

Cleaning is continuous.

Suitable for all neat and soluble oils.

## Product data

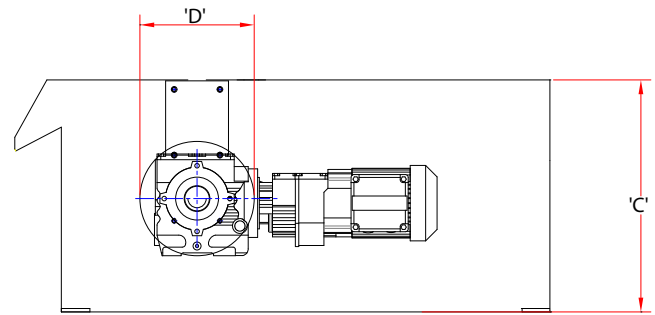
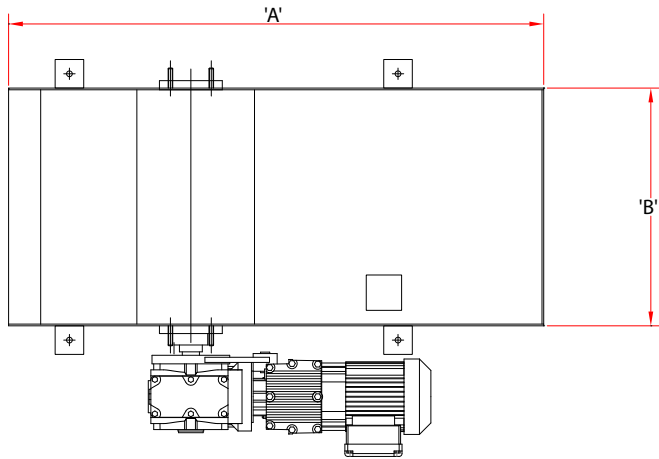

Part no.	A	B	C	D	Max flow ltrs/min.
ECC20/400	940	400	400	200	275

## INLINE OPERATION

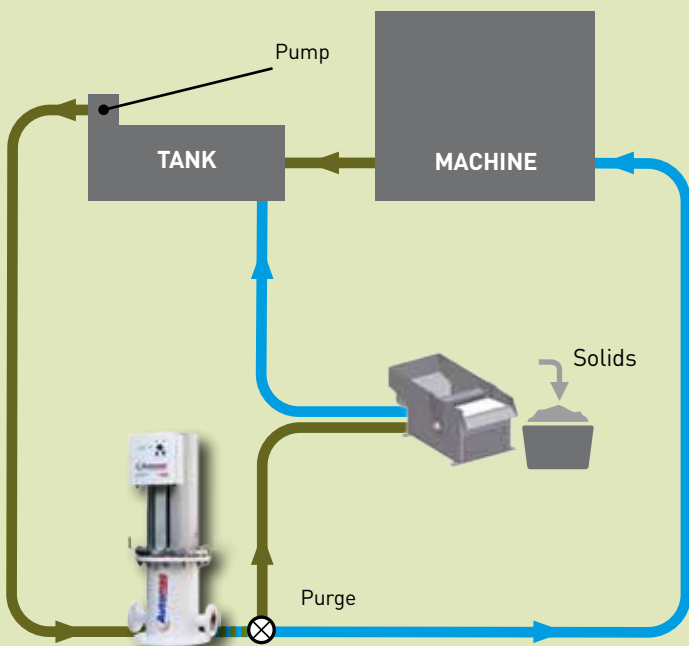

## OFFLINE OPERATION

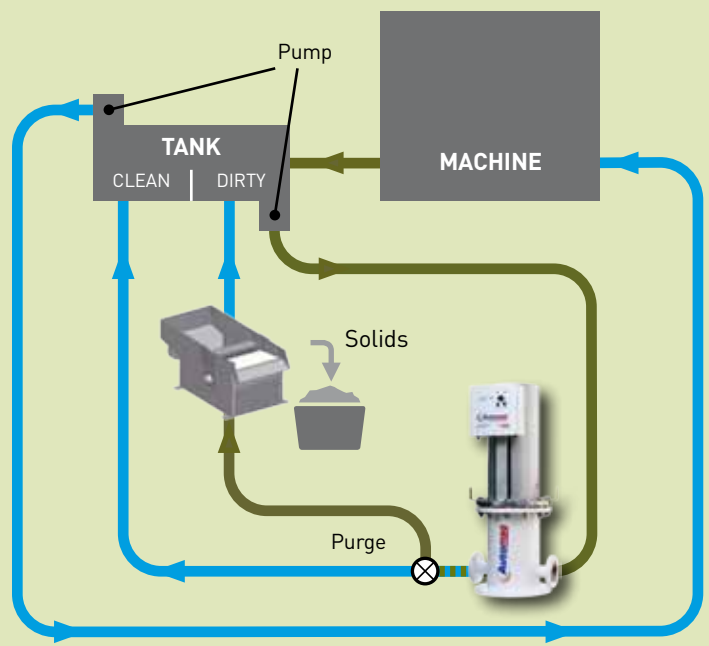

# The benefits of automated magnetic filtration

## No consumables required

Automag only requires small amounts of compressed air, which powers the process. It does not require filter cartridges, or any other filter media.

## Fully autonomous

Let operators do what they're good at: operating expensive and critical machinery. Automag can run 24/7 continuously without the need for operator intervention.

## No loss of fluid

Automag, when used with a purged fluid cleaning device, produces a dry 'cake' of contamination that can be recycled. Unlike cartridge filters no fluid is thrown away with contaminated filter media.

## No line pressure increase

Even when fully saturated with contamination the Automag never builds up the backpressure that causes burst socks or cartridges. The Automag's design ensures pressure is always maintained.

## No maintenance

The only moving part in the Automag system is the magnetic core shuttle. The magnetic cores are encased in stainless steel tubes; fluid does not come into contact with any moving parts.

## Sub-micron filtration

Automag removes sub-micron magnetic contamination, improving surface finish and overall machined accuracy.

## PLC compatible

All Automags can be supplied with a fully programmed PLC that can communicate with machine tools or auxiliary equipment. This also allows multiple Automags to operate in parallel.

# Product data

Higher flow, higher contamination  
 Non-stop operations  
 Harsh chemical environments

Inline/offline  
 Automated self-cleaning (air operated)  
 Full stainless steel construction  
 Temp. range: 5°C to 70°C  
 Multiple units can be grouped for higher capacity  
 Ex stock



Product number	Number of cores	Maximum flow rate		Contamination capacity	Max. operating pressure
		Litres/min.	m <sup>3</sup> /hour		
AMC	8	200	12	2.5	10
AM6	6	450	27	7	10
AM12	12	900	54	14	10

## Dimensions in mm unless stated

Product number	A	B	C	D	Port size
AMC	740	290	200	300	1½" PN16 flange
AM6	1065	395	275	450	2" PN16 flange
AM12	1145	565	405	620	3" PN16 flange

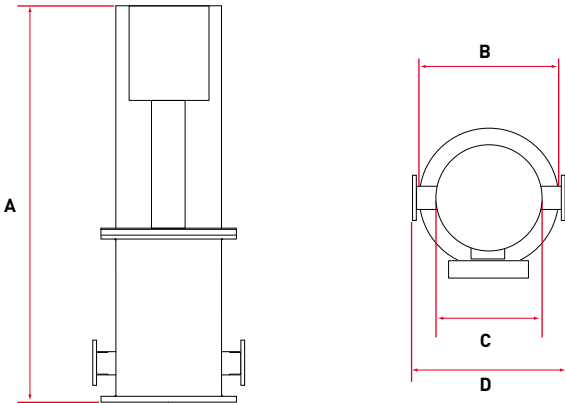

## Other Eclipse Magnetics filters



Compact, general purpose magnetic filter.  
 Most machining applications.



Larger filter for higher contamination capacity and flow rates. Precision grinding machines and fine finishing operations. Arduous environments.



Self contained filtration and fluid recovery system for higher flow, higher contamination applications. 24/7 automated operation.

[www.magneticfiltration.co.uk](http://www.magneticfiltration.co.uk)

### Eclipse Magnetics Ltd

Atlas Way, Sheffield, S4 7QQ, England  
 T +44 (0)114 225 0600 F +44 (0)114 225 0525  
 info@eclipsemagnetics.com www.eclipsemagnetics.com

